

JAMES L. GARVIN

FARRINGTON HOUSE

30 South Main Street Concord, New Hampshire, 03301

james@jamesgarvin.net

<http://www.james-garvin.com>

**REPORT ON THE FOGG-ROLLINS BARN
44 HAMPTON ROAD, EXETER, NEW HAMPSHIRE**

JANUARY 26, 2012

This report is based on a brief inspection of the surviving barn at the Fogg-Rollins property at 44 Hampton Road in Exeter on January 23, 2012. The inspection was made at the request of the trustees of the Fogg-Rollins Charitable Trust (also known as the Fogg-Rollins Trust). The purpose of the inspection was to assess the general condition of the barn, which is subject to a preservation easement granted in 2011 by the trustees of the Fogg-Rollins Charitable Trust to Historic New England (The Society for the Preservation of New England Antiquities). Present at the inspection were trustees Peter Smith and Dr. Edward Rowan, and consulting civil and structural engineer Fred S. Emanuel, P. E.

As previously requested by trustee Kenneth Turino, this report will provide an “assessment of what kind of work might be needed to stabilize and eventually restore the barn . . . [and] an idea of how structurally sound the building is and what needs to be done.” During the course of the inspection, an additional question arose. Potential purchasers of the property, who would be subject to the preservation easement, had examined the buildings on January 20, 2012 and had considered the possibility of converting the barn to residential use, an adaptation that is permitted under the terms of the preservation easement. The preservation easement permits, but does not require, the creation of “two (2) residential units contained in the barn” (Article 6.7). This permitted adaptation is conditioned by the limitation that the only exterior changes to the barn shall be the “installation of additional door and window openings in the west and north elevations of the Barn, provided that the grantee [Historic New England] approves the number, location, materials and design of new doors and windows” (Article 5.15) and that adaptation of the barn shall protect the integrity of “all structural members and framing, including but not limited to, interior beams, posts, girts, plates, studs, sheathing boards, rafters, purlins, masonry walls, and masonry piers” (Article 4.1). The potential buyers presented a brief written report asserting that it would not be feasible to adapt the barn for residential use.

Because adaptation of the barn is an optional choice of a future buyer, subject to the limitations mentioned in the easement, this report will not address the ramifications of exercising that option, but will confine its discussion to the original request of trustee Kenneth Turino. That request directly addresses the condition of the structural members that are protected under Article 4.1 of the preservation easement, quoted above. Assessment of the structural condition of the barn will, of course, have a bearing on the decision of a future purchaser as to whether to

preserve the barn as a barn, which is a minimum requirement of the easement, or to exercise the option of adapting the barn for residential use.

The existing Fogg-Rollins barn, which stands west of the house, is one of two that stood on the property until after 1925. The second barn stood behind (to the north of) the dwelling, attached to a milk house that remains in ruinous condition. This second barn reportedly housed milk cows and their provender. It disappeared many years ago.

The surviving barn is a gable-front or “Yankee” barn, with its gable end and main door facing east, toward the house. This barn was described in an 1854 deed of partition as “Gilbert [Rollins]s Barn.” Elizabeth Hengen states that “the existing barn belonged to him [Gilbert Rollins] as early as 1850,” citing the 1850 United States Census.¹

This barn represents the conversion of an English barn into the present elongated Yankee barn. The carcass of the earlier barn is intact within the front (eastern) section of the enlarged building, and its four rear posts can be discerned about two-thirds of the way toward the current rear wall of the structure, where framing changes from hewn to sawn. The original wall posts are heavy, and flared at the top; they reveal evidence of the former attachment of tie beams at their tops, removed when the orientation of the ridge was changed from north-and-south to east-and-west.

The original roof would have been composed of principal rafters and purlins, with the roof sheathing applied vertically, from eaves to ridge. The current roof frame is composed of sawn common rafters supported by a single sawn purlin on each slope; roof sheathing is laid horizontally. The general aspect of the barn as seen from the exterior suggests a date of enlargement at about 1850, the period when it was owned by Gilbert Rollins and devoted to his own uses. The fact that Gilbert Rollins had acquired and enlarged the original English barn of the Fogg homestead suggests that the second barn, behind the house, was probably built around 1850 by elder brother Obed Rollins to serve the needs of Obed’s separate household.



¹ Elizabeth Durfee Hengen, “Fogg-Rollins House, Exeter, New Hampshire: a Baseline Documentary Report” (2000), pp. 13-14.

The original English barn has a well-executed frame of a standard form, as shown in the generic diagram of an exploded upper corner, below. The tops of the posts measure about 10" by 12".

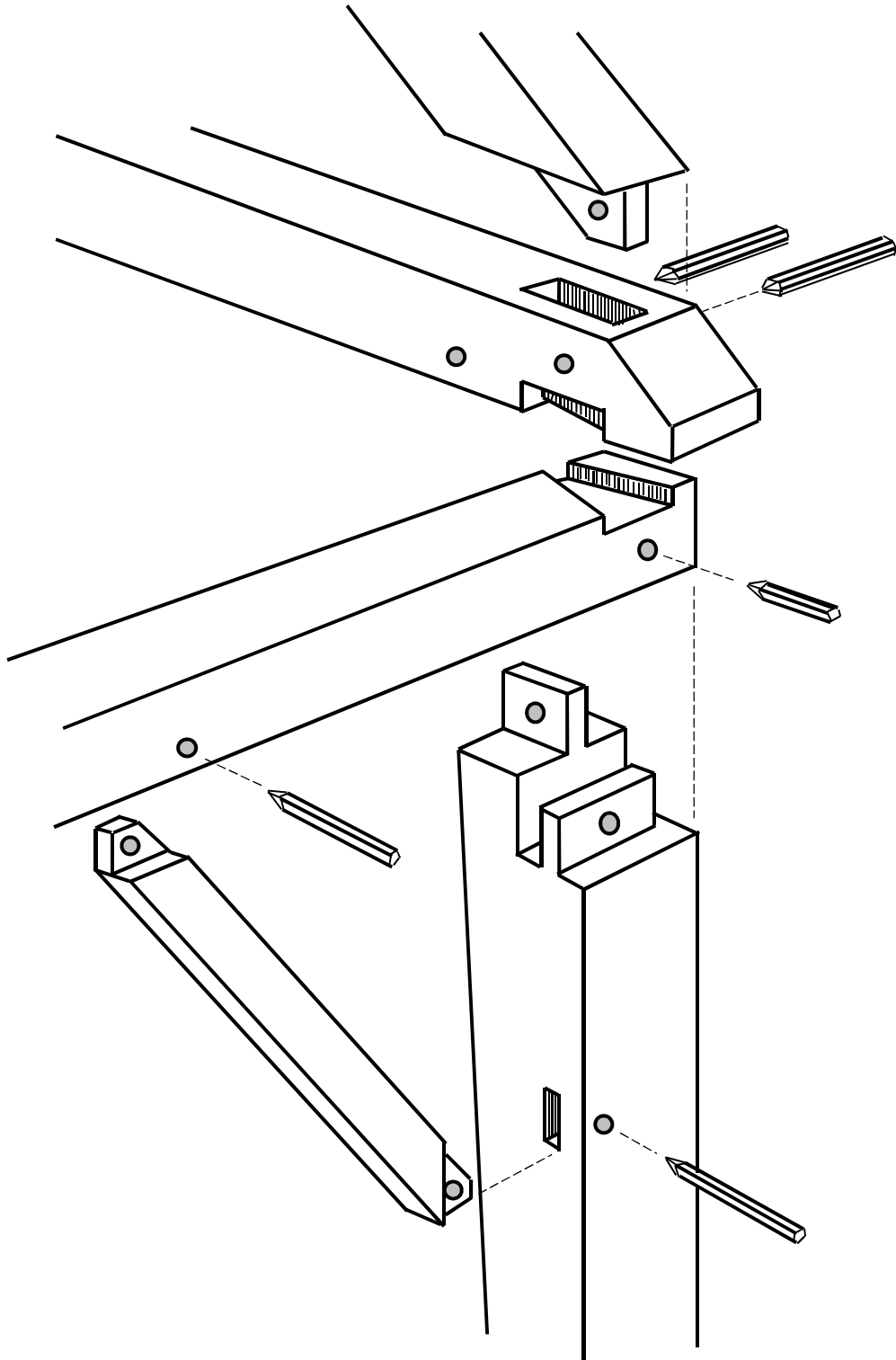

The layout of the barn frame is shown below. The original English barn measured approximately 33'-6" in its broad dimension (north-south) and approximately 24'-0" from front to rear (east-west). Its main door faced east, toward the nearby dwelling.

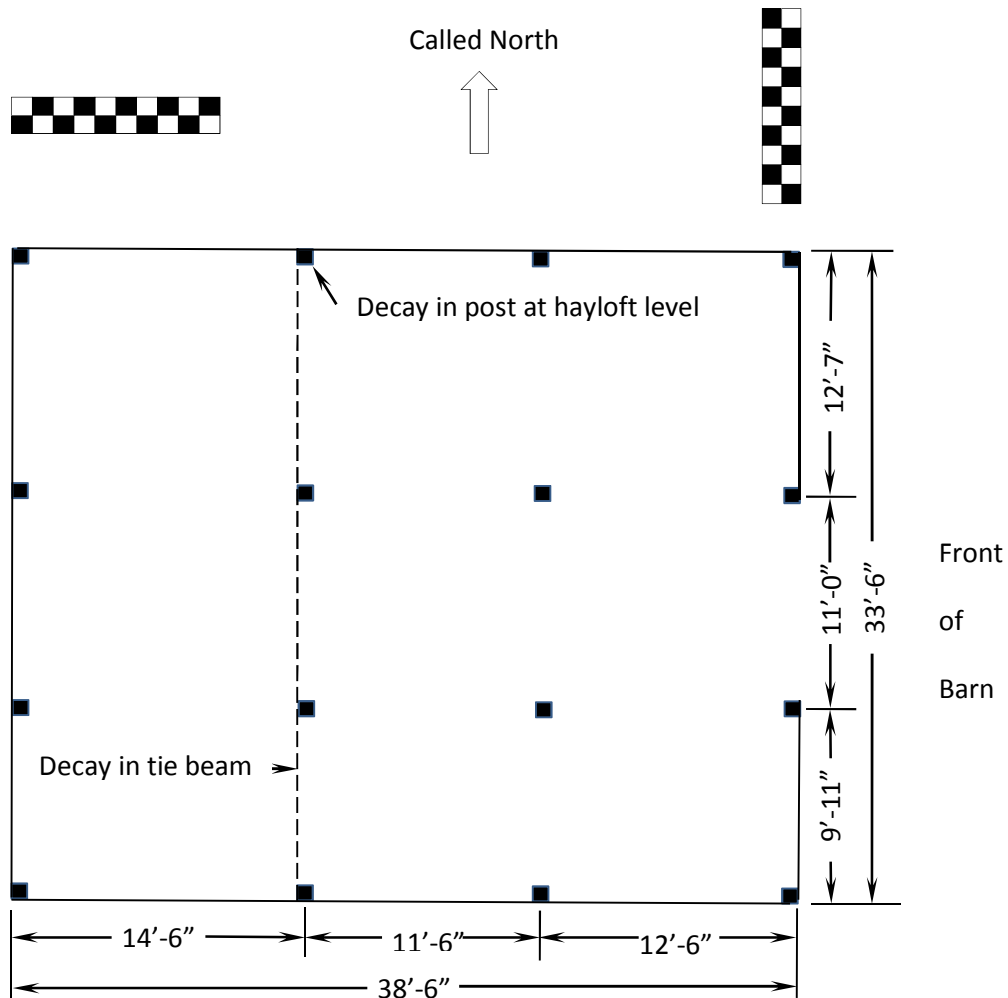

The framing of the original barn, and of the barn as extended, enlarged, and reoriented, is shown in the two simplified drawings on the following page. A multitude of smaller framing elements are omitted from these drawings for clarity, including hayloft framing on each side of the central driveway, braces, and horizontal nailers that are used to secure the vertical barn sheathing at various elevations along the walls of the structure.

The original barn frame is heavy and hewn from pine. The newer frame is sawn on a reciprocating (upright) sawmill. The single hewn timber noted in the new frame is the tie beam at the feet of the rear (western) pair of rafters. This framing member has a length of about 33'-6", and that length was apparently beyond the capacity of the carriage of the sawmill that was employed to saw out the rest of the new frame.

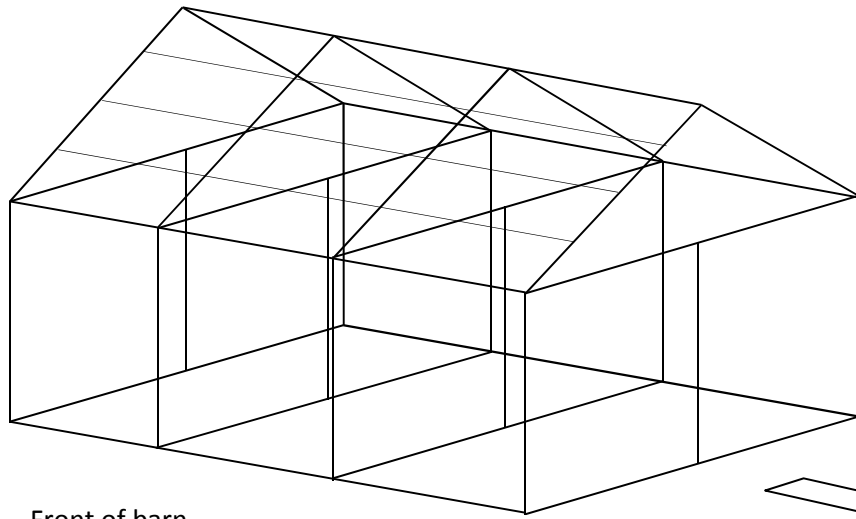

Front of barn

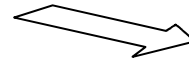

Called North

Original English barn frame. Wall braces and rear roof purlins are omitted for

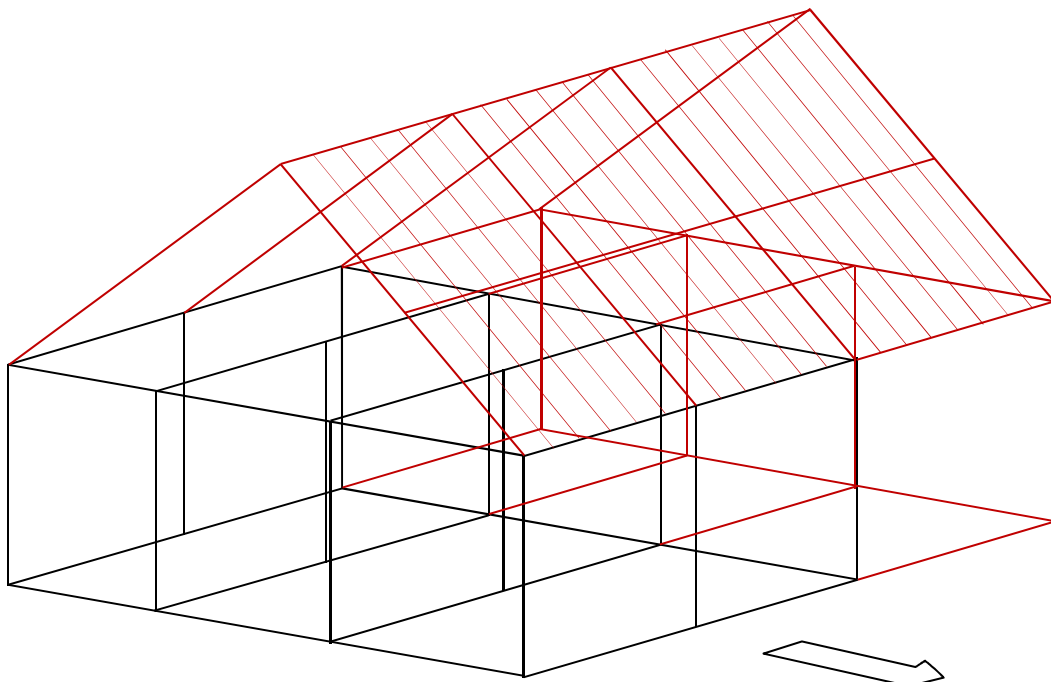

Front of barn

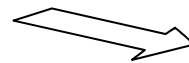

Called North

Barn as enlarged circa 1850. New framing elements are shown in **brown**.
Wall braces and rear roof purlins and rafters are omitted for clarity.

While the original barn frame was carefully assembled with complex joints like those shown on page 3, the mid-nineteenth century frame appears to have been spiked together in certain areas, as where the rafters rest upon the north and south wall plates. The single area where more traditional and complex framing was utilized is in the assembly of the new roof membrane. Here, the single central purlin is tenoned into the sides of the heavy principal rafters, and the light common rafters are similarly tenoned into the purlin, as shown below.

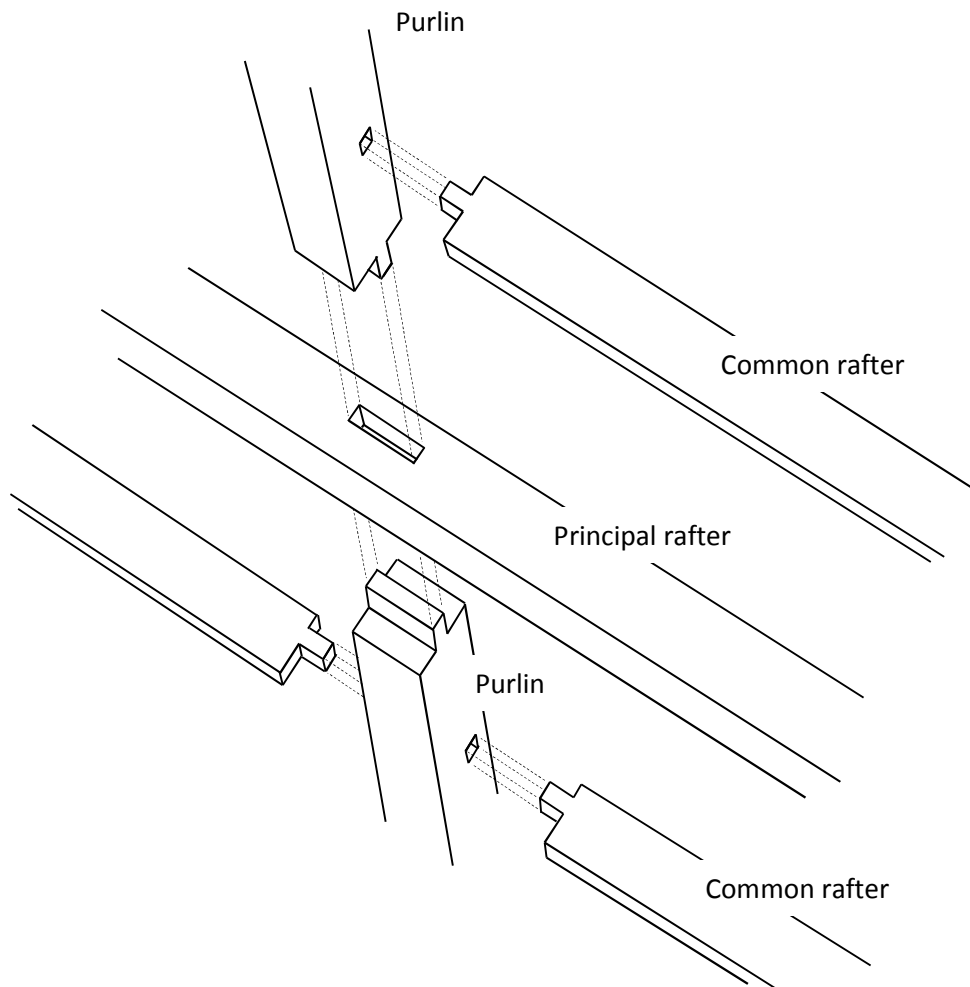

The principal rafters and purlins measure about 7" by 7." The common rafters measure 2" by 5."

The use of this type of frame, combining principal and common rafters, can be traced back to the seventeenth century, especially in Massachusetts. It is seldom encountered in New Hampshire in the eighteenth century except in the roof frames of large meeting houses. By the mid 1800s, however, this method of roof framing saw a resurgence, especially in roof frames composed of

sawn members, as in the Fogg-Rollins barn, and even more commonly in the roofs of church buildings. Its use here is characteristic of the period when the barn was enlarged.

General condition of the barn. The Fogg-Rollins barn is in structural distress and is in need of stabilization and eventual repair in order to fulfill the preservation requirement of the easement. The structural problems now evident in the building result from several causes. Chief among these are old roof leaks, which caused localized deterioration in former times; and ongoing subsidence or shifting of supports beneath the structure. The behavior of the barn under these conditions reflects the fact that the body of the building is composed of two attached frames, as shown in the diagrams on page 5. Discontinuity in the wall framing has probably increased the distress that the building has suffered as its support has subsided.

Substructure. The barn is supported on perimeter foundation walls of irregularly placed dry-laid fieldstone and boulders, and on interior piers that for the most part are posts of split granite. The splitting technology of the granite posts denotes a date after circa 1830, so it may be theorized that most of the split granite piers under the barn were added when the barn was enlarged in the mid-1800s.



In many if not most cases, these supports have shifted or subsided, often having tipped as a result of uneven freeze-thaw cycles in the soil around their feet. A number of supplementary piers of timber and/or concrete blocks have been inserted at points of lost support, as seen above. In many cases, the barn frame above these points of support had deformed and settled before supplementary piers were added. The frame of the barn, especially the newer or western portion, thus remains in distorted condition, as described below.

Frame. As described above, the frame of the barn as it stands today dates from two periods: the late 1700s for the eastern portion, composing the carcass of the original English barn of the Fogg farm; and the mid-1800s, being represented in the western structural bay and the entire roof frame of the building, as shown on page 5.² With certain exceptions, much of the upper framing of both parts of the barn remains in generally sound condition, having been isolated from dampness and affected only to a limited degree by old roof leaks. The framing of the main floor of the barn, and of the haylofts on each side of the central driveway, is mostly composed of sleepers—natural tree boles hewn flat on their upper sides to receive floor boards—as seen in

² For details on the builder of the house and (presumably) the barn, and later occupants of the property, see Elizabeth Durfee Hengen, “Fogg-Rollins House, Exeter, New Hampshire: a Baseline Documentary Report” (2000).

the photographs on page 7. A few of the hayloft joists of the newer western extension are square, sawn timbers.

As might be expected, the perimeter sills of the barn, being close to the ground and affected by rainwater falling from the eaves of the roof, have suffered varying degrees of decay. This is especially true on the south side of the barn, facing Hampton Road. Here, as is usual with wooden buildings, the eroding effect of ultraviolet light from the sun has accelerated the deterioration of the vertical sheathing boards, leaving the southern sill of the structure especially exposed to rainwater from the roof, as seen in the photograph below, left.



The sills on the northern and western sides of the barn, though nearer to the ground, have been better protected by relatively intact sheathing, and appear to be in acceptable condition, as seen above, right.

Although the upper frames of both old and newer sections of the barn are in better condition than the perimeter sills, the rear wall plate of the original English barn, indicated by the dashed line on the plan on page 4, exhibits pockets of decay. This deterioration apparently resulted from a chronic leak on the western slope of the roof of the original barn. This wall plate now functions as a lateral tie beam at the feet of principal rafters of the newer, reoriented roof frame. The decay has probably not advanced appreciably since the barn was lengthened circa 1850.

There is evidence of former chronic leaks on both slopes of the newer roof, above the western bay of the extended structure. Water has penetrated the roof and rotted the floor boards of the haylofts on both the north and south sides of the central driveway.

There is also decay at the original northwest corner post of the English barn, as indicated on the plan on page 4. Whether this resulted from an old leak before the barn was enlarged, or occurred because of one of the roof leaks in the enlarged barn, mentioned above, remains to be determined by further examination.

More serious than these older leaks is an active leak near the northeastern corner of the barn, shown in the photograph on page 9, left. This leak reportedly began with roof damage from a falling branch of a large sugar maple that stands just east of the barn. The branch damaged the

rake of the roof and penetrated the sheathing above the outer principal rafter, at a critical point just above the joint between the rafter and the purlin, as shown below, right. The leak was never repaired, and water penetration has progressively rotted the rafter at its center point, and the end of the purlin, threatening the integrity of a substantial portion of the northern roof plane. Continued water penetration here also threatens the original wall plate of the English barn, seen at the lower left corner of the photograph below, right.



This point of structural weakness can be temporarily supported by props extending up from the tie beam to the undersides of the rafter and purlin.

A more pervasive threat to the barn is the severe racking and twisting of the entire structural fabric, caused by the subsidence of the underpinning and piers, described on page 7. This movement has caused both localized and generalized distress, and now threatens the stability of the entire structure. Readings taken by Fred Emanuel on January 23, 2012, indicate that the barn is out of plumb by 4 inches in 48 inches from north to south, and 1¼ inches in 48 inches from east to west. As seen on page 8, an attempt has been made to prop the barn on its north side.



The degree to which the barn leans to the north can be seen by sighting along its southern wall toward the plumb walls of the dwelling beyond, as shown in the photograph at the left.

The racking of the frame has been worsened by the removal of many of the original braces of the frame of the English barn. When the barn was enlarged in the mid-1800s, many internal braces of the old frame were deliberately removed, apparently out of a desire for less internal obstruction and in the belief that the intact braces in the outer walls of both old and new frames would be sufficient to stiffen the entire structure. This might have been true if the frame had remained plumb, but subsidence of the footings has created the movement described above.

One effect of that movement has been the overstressing of some of the mortise and tenon joints of the older frame. A joint at the hayloft level in the southwest corner post of the old frame, for example, has begun to pull apart. The pin or treenail in this joint has apparently sheared from the tensile forces exerted on the tenon by the tipping of the barn and the subsidence of the former rear wall post located next north from the corner of the original barn.

The considerable distortion of the frame through subsidence, tipping, and racking is visible on the southern elevation of the structure, as seen below. Particularly noticeable is the depression in the southwestern quadrant of the roof. This is caused by the subsidence of the former rear wall post of the English barn, mentioned above, which has telegraphed its movement to the rafter and purlin above. As seen in the diagram on page 6, the structure of the roof of the enlarged barn is not exceptionally heavy, and subsidence of a principal rafter and a purlin will be followed by subsidence of the lighter common rafters, and of the entire roof plane, as seen below.



There have been attempts to restrain the movement of the upper frame of the barn. There was apparently a perception in recent years that the upper walls were spreading and the roof was flattening, probably due to snow loading. For this reason, considerable effort was made to tie the north and south walls of the structure together through the insertion of sistered ties through the barn at the level of the wall plates, as seen in the photograph on page 11. Similarly, a number of collar ties were nailed to the sides of both principal and common rafters at about the midpoint of the height of the roof frame. These new members are all two-inch planking.



Sheathing. The wall sheathing of the barn is applied vertically, as is common with barns. Many sheathing boards on the English barn were sawn on a reciprocating saw, and are old if not original; examination of the nails that hold the boards will help to date their application. Where they survive in good condition, the sheathing boards have tongued-and-grooved joints. The barn walls appear never to have been shingled.

The sheathing on the north side of the barn survives in generally good condition. The sheathing on the south elevation is badly eroded and decayed, especially at its lower ends, as seen in the photograph on page 10. The quality of sheathing on the old English barn is superior to that of the mid-nineteenth-century extension, both in width of boards and freedom from knots.

As seen in the photograph on page 10, there is severe deterioration at mid-height in the newer boarding at the western end of the south elevation. The fracture of the boards suggests failure in compression, apparently caused by subsidence of the upper frame. (The area covered by plywood is a row of window sashes that were apparently salvaged from the dwelling when it was remodeled in 1854 and now light a former hennery in this part of the barn.)

For the protection of the underlying framing elements cited in the preservation easement, it will be necessary to replace much of the sheathing on the south elevation of the barn. It may be possible to preserve the upper portions of boards that remain in acceptable condition, re-covering the lower zones of the wall. This has been done on portions of the north and west sides of the building, as seen in the right-hand photograph on page 8.

Roofing. The roof shingles of the barn are in failing condition, at least on the southern slope, as shown in the photograph on page 10. This slope was formerly covered with a polyethylene tarpaulin, which has rotted and blown away, suggesting that the roof was actively leaking, yet no sign of water or ice was noted inside the building during the inspection on January 23.

The horizontally applied roof sheathing boards appear generally sound, as do the principal and common rafters. At one time, as noted on page 8, there were chronic leaks in both the north and south slopes of the roof. Water rotted the floor boards of the haylofts on both sides of the central driveway. Today, the roof sheathing appears to be intact above these areas of rotted flooring, suggesting that portions of the roof were re-sheathed at some time.

Recommended treatment. The Fogg-Rollins barn needs both short-term and long-term remediation of its problems if it is to survive in accordance with the preservation easement.

Short-term treatments must start with repair of the damage and leak near the northeast corner of the roof. Because of the crucial function of the principal rafters and purlins in this roof, and because this leak is precisely above the juncture of two such members, the leak threatens the entire slope of the roof. After the leak is repaired, it would be advisable to extend wooden props from the beam below the leak to the decaying rafter and purlin to ensure their support until the rafter can be replaced. At present, it is possible that the decayed front rafter is being supported and prevented from breaking largely by the vertical sheathing boards that are nailed to its side.

Because the roof shingles are in failing condition, they will require quick replacement. Even if it is not yet leaking, a roof in this condition can deteriorate very rapidly under certain weather conditions and develop pervasive leakage in a matter of weeks. Because the south roof plane is distorted and will need to be returned to its proper geometry through repairs to the frame, it may be advisable to strip the roof and cover the sheathing temporarily with roll roofing, pending the straightening of the frame. If the roof covering should be torn during straightening of the building, the monetary loss will be considerably less with a papered roof than with a shingled roof.

Because the modern ties of two-inch planking that were added to the roof frame do not extend continuously across the entire building, they have limited effectiveness in restraining the structure in its leaning condition. Pending the jacking of the building and its return to plumb and level condition, consideration might be given to cabling the structure from within to prevent its continued distortion, especially in the north-south direction.

Long-term treatments will include standard types of repair to a barn in stressed condition. Repair of historic barns has become increasingly commonplace as people have realized their value and their vulnerability to neglect and decay. Standard treatments include jacking and leveling the entire building, placement of solid and effective perimeter foundations and footings beneath the structure, replacement of perimeter sills and interior girders where necessary, in-kind replacement of failed members, and sistering or reinforcement of members that are weakened by decay or overstressing yet do not require replacement. In keeping with the intent of the preservation easement, all future work on the barn should preserve the maximum amount of

early material, replacing members only when they are in failed condition and are a detriment rather than an asset to the integrity of the structure.

Once the frame has been returned to its proper geometry, its frame will require protection from the elements. As noted above, the condition of the exterior sheathing of the barn varies widely across the building, ranging from nearly perfect to completely absent. In the interest of protecting the frame, it will be necessary to develop a plan and specifications for repairing the exterior cladding of the walls. It should be possible to obtain white pine or hemlock boards of average widths that are visually compatible with the existing boards, and to have such boards jointed and tongued-and-grooved.

There are a number of specialists in barn repair within a reasonable radius of Exeter. Many of these artisans are experts in cribbing, jacking, leveling, and timber framing. Their accustomed work closely matches the needs of the Fogg-Rollins barn. Attached to this report is a list of such specialists, compiled by the New Hampshire Division of Historical Resources in 2003 and updated from time to time.

Respectfully submitted,
James L. Garvin

**CONTRACTING FIRMS SPECIALIZING IN REPAIRING, DISASSEMBLING,
AND RE-ERECTING BARNs AND OTHER OLD BUILDINGS**

This list has been prepared as an aid for those who may require specialized services. It is not an endorsement of those listed, and it is not intended to limit a client's choice. Names appear alphabetically. The New Hampshire Division of Historical Resources is not responsible for a consultant's scope-of-work or work performance.

Timothy Andrews
Barns and Bridges of New England
9 Damson Lane
Gilford NH 03249-7867
603-293-0402

Stephen P. Bedard
PO Box 430
Gilmanton NH 03337
603-524-1773

Tim Desclos
Vintage Home Restoration Co.
PO Box 1137
Hollis NH 03049-1137
603-465-9533

Steve Fifield
Fifield Building Restoration & Relocation
Shaker Road
Canterbury NH 03224
603-783-3345

Arnold M. Graton & Associates Inc.
P O Box 174
Holderness NH 03264
603-968-9574 / 603-968-3621

Arnold M. Graton, Jr.
7 Luneau Court
Northfield NH 03276
603-286-4055

Great Northern Barns
White River Junction VT 05001
802-295-7616
603-523-7134

Donald Guarino
D. Guarino Construction
RFD #1, Box 1324
Gilmanton NH 03237
603-267-8273

John Libby
Barn Masters, Inc.
PO Box 258

Freeport ME 04032
207-865-4169

David Ottinger
24 Mount Delight Road
Deerfield NH 03037
603-463-7451

Derek Owen
Owen Associates
580 Brockway Road
Hopkinton NH 03229
603-225-2252

Ed Pape
1246 Parker Mountain Road
Strafford NH 03884
603-664-2760

Robert L. Pothier, Jr.
First Period Colonial
PO Box 31
Kingston NH 03848-0031
603-642-8613

Mark Phillips
North Fields Restoration, Inc.
Route 1, PO Box 575
Hampton Falls NH 03844-0575
603-926-5383

Gregory Schipa
Weather Hill Restoration Company
PO Box 113
Charlotte VT 05445-0113
802-425-2095

Bayne Stevenson
River Road
Lyme NH 03768
603-353-4820

Arron J. Sturgis
Preservation Timber Framing Inc.
P.O. Box 29
Eliot, Maine 03903
207-439-9722